

THE FRANCK-HERTZ EXPERIMENTS, 1911–1914

EXPERIMENTALISTS IN SEARCH OF A THEORY



James Franck



Gustav Hertz

Clayton Gearhart
St. John's University (Minnesota)

University of Minnesota—Duluth
25 September 2014

EXPERIMENTAL PHYSICS



Now, the whole situation was of course entirely different then. A physicist worked essentially with the hands. I mean, also some with the head, but the greatest part of the day, it was certainly manual work.

Gustav Hertz
Lindau lecture, 1968

FRANCK AND HERTZ IN 1914: THE TEXTBOOK VIEW

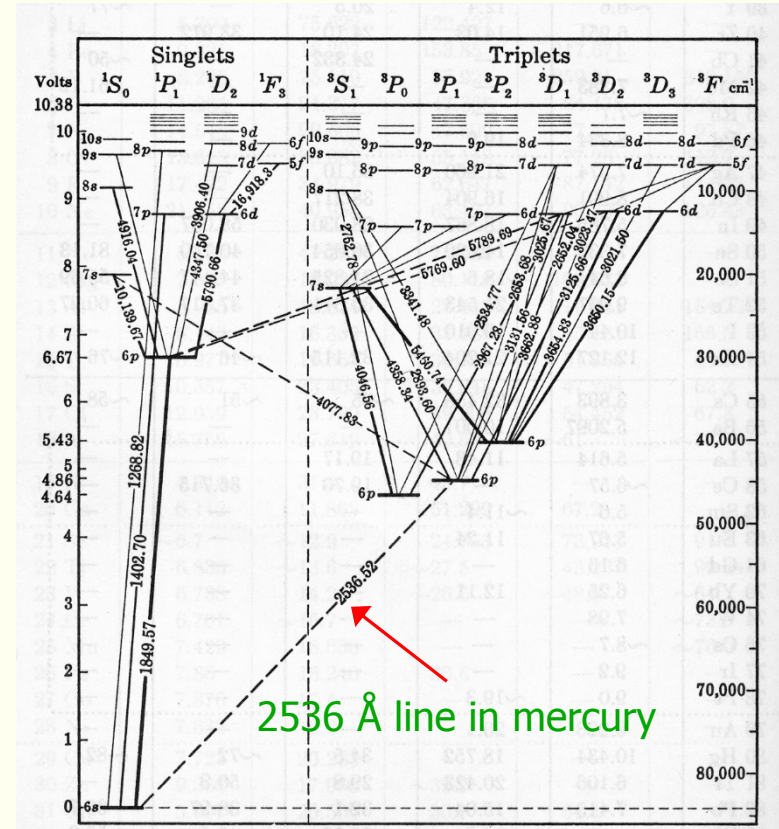
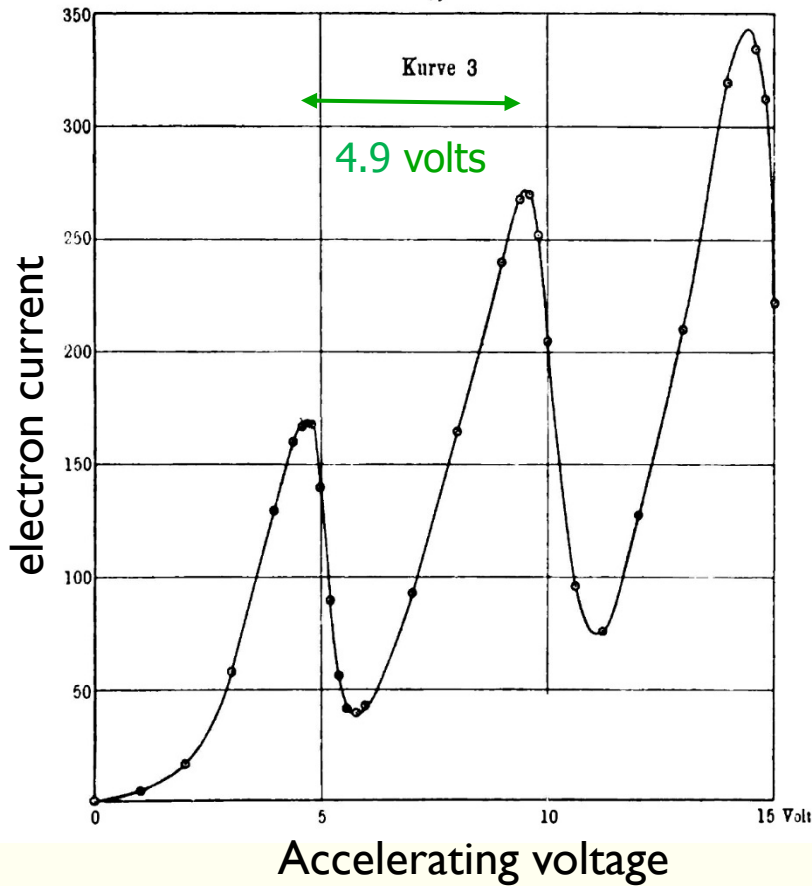

In 1914, Franck and Hertz bombarded mercury vapor atoms with slow electrons.

- the peaks in their graph of electron current vs. accelerating voltage as the onset of inelastic collisions, in which energy was transferred to the mercury atom.
- This energy, 4.9 eV, corresponds to the 2536 Å “resonance” line in mercury
- Conclusion: The transferred energy raised the mercury atom to an excited state, just as the Bohr picture of stationary states predicts.

UNFORTUNATELY ...

- Franck and Hertz did not so much as mention Bohr's theory in 1914
- They began their collaboration in 1911, well before Bohr's theory.
- They thought they were measuring ionization potentials, *not* excited states.
- They had an older and entirely different (Thomson-like) picture of electrons in atoms.

... in every mercury atom an electron is present that can oscillate with a frequency corresponding to the wavelength 253.6 μm .

Franck and Herz, 1914

- Even worse:

The original goal of our experiments had nothing to do with atomic or quantum physics.

Gustav Hertz, 1975

WHAT WAS THEIR ORIGINAL GOAL?

WHAT WAS THE CONCEPTUAL AND EXPERIMENTAL CONTEXT?

THE PHYSICAL INSTITUTE, UNIVERSITY OF BERLIN



James Franck
Ph.D. 1906
gas discharge,
ion mobility

Physics in Berlin, early in the 20th century:

- close-knit group of young, enthusiastic experimentalists
- J.J. Thomson, the Cavendish Laboratory, and the electron
- quantum theory (Planck, Nernst, Einstein ...)

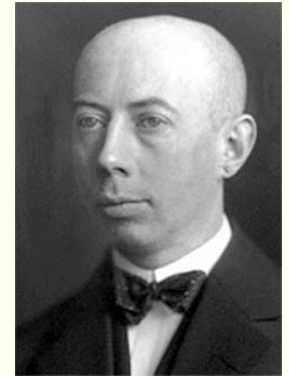

Gustav Hertz
Ph.D. 1911
IR absorption
in CO₂

THOMSON, RUTHERFORD, AND THE CAVENDISH

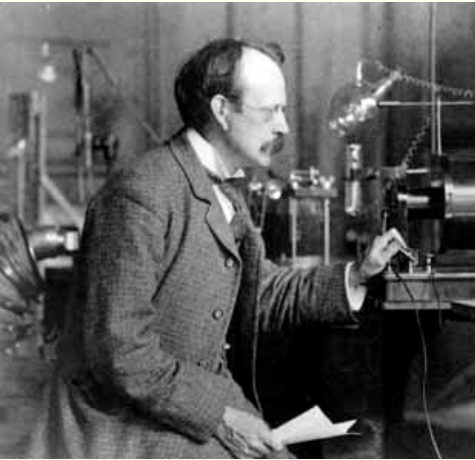

J.J. Thomson



Ernest Rutherford
Arrived at
Cavendish in 1895

The study of the electrical properties of gases seems to offer the most promising field for investigating the Nature of Electricity and the Constitution of Matter

J. J. Thomson
Conduction of Electricity through Gases (1903)

J. J. Thomson was our physical Bible. We had to look at his things and to read it and reread it.

James Franck
1962 Interview

RUTHERFORD AND ION MOBILITY

The newly discovered electron and other equally new phenomena—x-rays, radioactivity, and the photoelectric effect—not only opened new and exciting windows into nature, but also made possible an unexpected range of new experimental techniques.

Electrical conductivity in gases became a central theme.

Thomson and his students, including Ernest Rutherford, the American John Zeleny, and John Sealy Townsend, **had ionized gases using x-rays, ultraviolet light, and alpha emitters.**

Ion mobility: The constant speed at which an ion moves under an electric field of 1 volt/cm. For common gases at **atmospheric pressure**, these mobilities are on the order of a few cm/sec, with negative ions having slightly larger mobilities than positive ones. **These negative ions were not electrons).**

Rutherford had in fact developed two different experimental techniques for measuring ion mobilities (1897 and 1898), following joint paper with J. J. (1896).

This history is not especially well known.

RUTHERFORD AND ION MOBILITY

Method I: Subject a gas streaming down a tube to a perpendicular electric field.

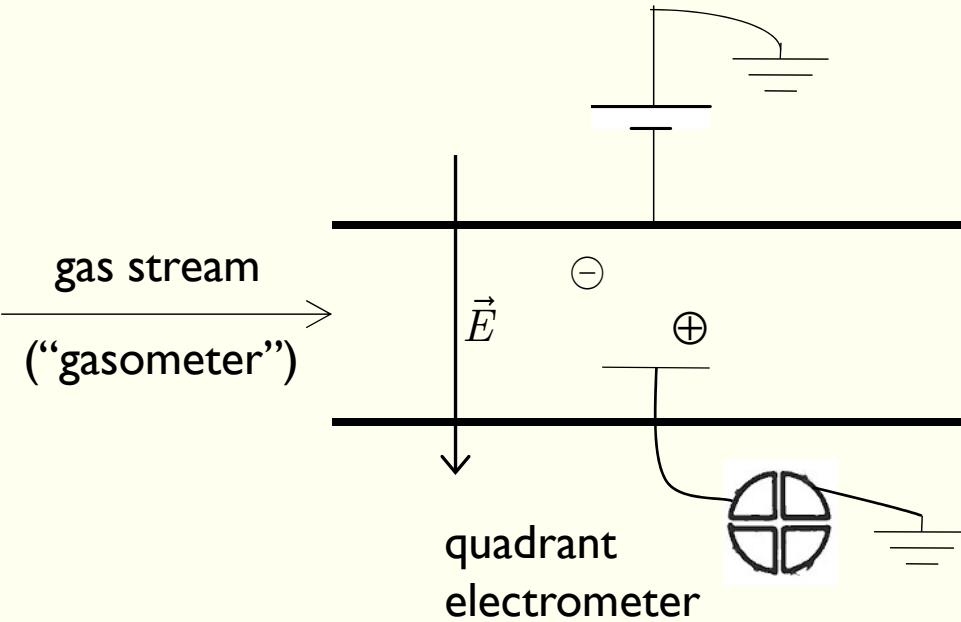

measure velocity of gas stream, time for electrons and positive ions to reach electrometer
⇒ calculate mobility

Disadvantages:

- required large quantities of gas
- initially, could measure only sum of +, - ion mobilities
- John Zeleny later measured +, - mobilities separately

RUTHERFORD AND ION MOBILITY

Method 2 (1898 version):

- uv light liberated photoelectrons electrons, which immediately formed negative ions
- so only mobilities of negative ions measured
- Ions entered a chamber in which they moved under the influence of an electric field that rapidly changed direction.
- Thus, depending on the frequency and amplitude of the electric field and the distance between the electrodes, the ions might or might not reverse direction before striking a collecting electrode that was connected to an electrometer.
- The rapid increase in the electrometer reading when ions were collected allowed an straightforward calculation of the mobility.
- apparatus enclosed in a bell jar \Rightarrow pressures lower than atmospheric possible

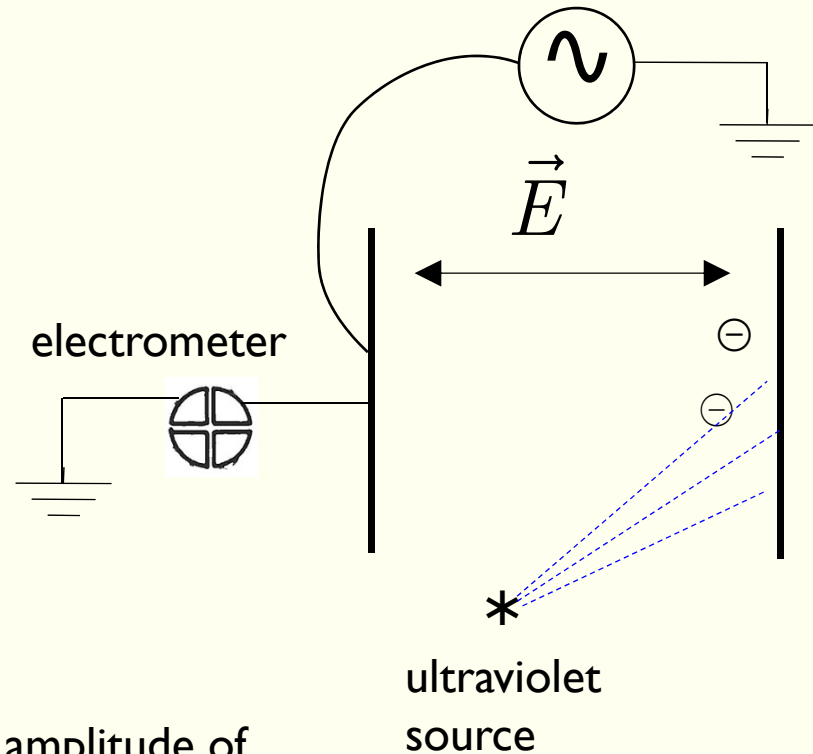

FRANCK AND ION MOBILITIES: 1906



James Franck

Franck began Ph.D. research with Emil Warburg at the Berlin Physical Institute, working on “point discharges” in gases

- decided to work on ion mobilities for ions created by point discharges
- first tried Rutherford’s method 1; results inconsistent with Zeleny
- then turned to Rutherford’s method 2



Emil Warburg

point (or corona) discharge

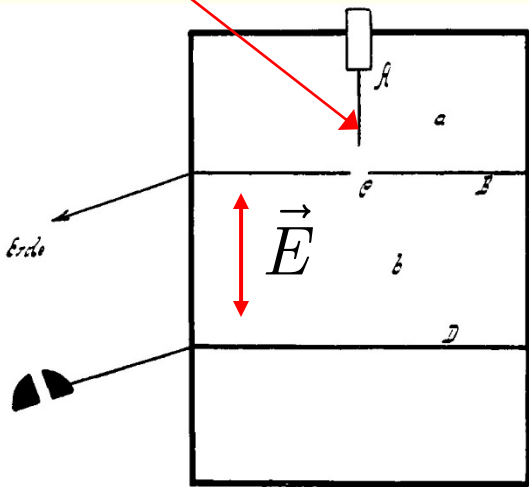

Fig. 4.

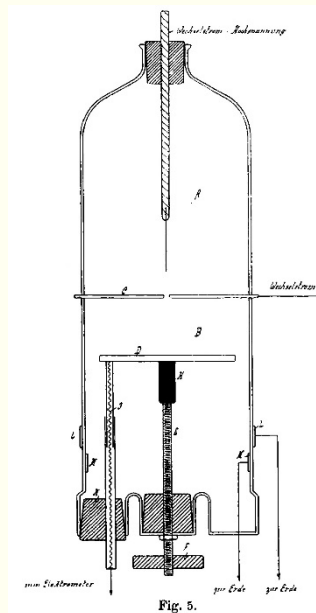

Fig. 5.

This time, Franck found mobilities in air consistent with Zeleny’s results.

- measured mobilities of both positive and negative ions
- note technique: ions created by discharge in separate (top) region; migrated into measurement region through small opening in top plate

FRANCK AND ROBERT POHL: ION MOBILITIES, 1907



James Franck

In 1907, Franck and Robert Pohl measured ion mobilities using a new version of Rutherford's Method 2:

- used small amounts of highly purified gas ($\sim 30 \text{ cm}^3$)
 \Rightarrow could measure mobilities for rare and expensive gases such as helium
- used alpha emitter to create ions \Rightarrow could measure **both** positive and negative mobilities



Robert Pohl

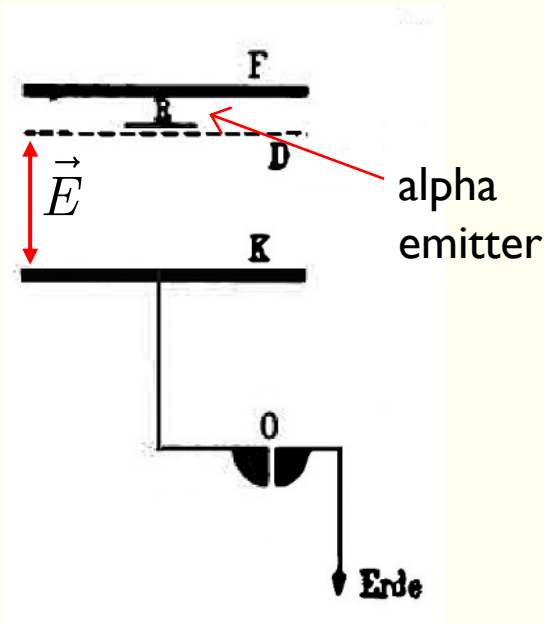

Note similar technique: ions created in separate (top) chamber; moved into lower measurement chamber through mesh top electrode.

- confirmed Zelany's results for a few gases (e.g., air)
- measured mobilities for helium—similar to above (a few cm/sec)

To this point, Franck had shown himself to be a clever and innovative experimentalist; but results were hardly earth-shaking.

FRANCK AND ION MOBILITIES: 1910

In 1910, Franck returned to this technique to measure mobilities in mixtures of argon and diatomic gases at atmospheric pressure.

- picked argon because its mobilities had not been previously measured.
- mobility of positive ion in argon about as expected, 1.37 cm/sec); BUT
- mobility of negative ion was huge, about 200 cm/sec

This investigation produced an extraordinary [merkwürdig] result ...

- mobility slowly decreased over several days
- addition of 1.5% oxygen decreased mobility to about expected value (1.7 cm/sec)
- similar behavior in nitrogen
- Franck asked: Why not in helium? (later turned out: more sensitive to contaminants)

Conclusion: Electrons in argon remained free, even at atmospheric pressure; they did not immediately combine with neutral molecules to form negative ions.

Hertz later stated emphatically that this result led directly to their experiments on **ionization by collision**. To see why ...

JOHN SEALY TOWNSEND



Educated at Trinity College Dublin, where he studied mathematics and physics; graduated in 1890.

Came to the Cavendish in 1895, at the same time as Rutherford

Quickly made a name for himself as an experimentalist:

- Among many other achievements, he made the first measurement of the charge on the electron; his technique influenced later experiments, including Robert Millikan's—as Millikan acknowledged in his book.
- in 1899, was made a fellow of Trinity College, Cambridge
- became the Wyckham Professor of Physics at Oxford in 1900

John Sealy Townsend

He wanted nothing to do with either relativity or quantum theory, and never accepted the Franck-Hertz discoveries. His reputation probably suffered as a result.

JOHN SEALY TOWNSEND AND IONIZATION BY COLLISION

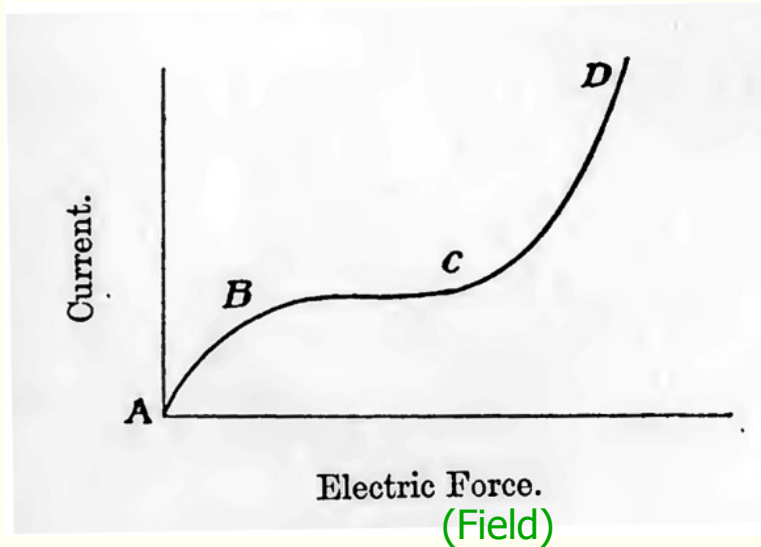

In 1900, Townsend published the first in a series of papers investigating collisions of low-energy electrons (“negative ions”) with gas molecules.

He created electrons using the photoelectric effect or x-rays and accelerated them in an electric field, at pressures of, typically, a few mm of mercury.

The graph, taken from the first page of his 1910 book, illustrates his results.

The current rose steadily and then leveled off: In the region BC, *all* newly created electrons were collected at the positive electrode, so an increase in electric field could not increase the current. This much had been discovered earlier by Thomson and Rutherford.

Townsend discovered that at higher fields, collisions created new electrons, thus starting a cascade effect at C in which the current rose rapidly. These cascades took place at electron energies **much lower** than those typical of cathode rays.

... it is necessary to attribute to ions [electrons] moving with comparatively small velocities the property of producing ions from molecules of the gas ... (Townsend 1915)

JOHN SEALY TOWNSEND AND IONIZATION BY COLLISION

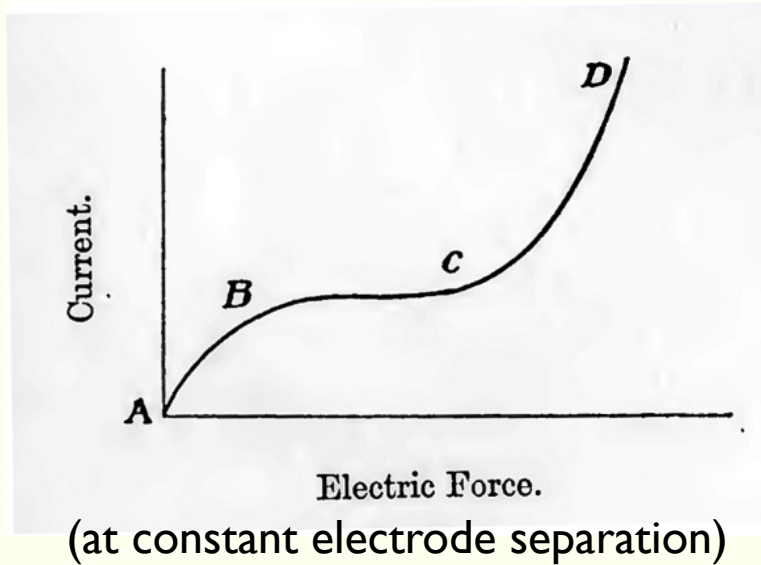

Townsend found he could describe the current produced in these cascades with a function involving an exponential term $e^{\alpha x}$

where α is the number of new “ions” (electrons) created by collision as the original ion moves 1 cm in an electric field of 1 volt/cm and x is the distance through which the electron moves.

This scheme described his data reasonably well; but in addition, Townsend derived a **theoretical** expression for α :

$$\alpha = \frac{1}{\lambda} e^{-\frac{V}{\lambda X}}$$

where λ = mean free path

V = ionization potential

X = electric field

Plausible estimates for V and λ led to reasonably good numerical agreement with his experimental values for α . These values of V , for different gases, were his reported ionization potentials. **BUT**

His derivation assumed that electrons lost all of their energy in collisions, even when the electron kinetic energy was smaller than the ionization potential.

FRANCK AND TOWNSEND

HOW DID FRANCK PUT ALL THESE THEMES TOGETHER?

- After 1910 papers, Franck quickly became dubious about Townsend's theory
- Franck in 1910 (and later) also cited British papers showing that at high (atmospheric) pressures, helium conducts electricity comparatively easily
 - ⇒ easy to ionize
- If energy always lost in collisions (Townsend), then an electron must take on ionization energy as it runs through a **single** mean free path
 - ⇒ only two ways in which easy conductivity of helium possible
 - low ionization potential; or
 - very long electron mean free path

Nature of collisions:

- even at high pressures, electrons were apparently “reflected” from molecules, and not absorbed to form negative ions
- And if they were reflected, **how much** energy did they lose?

Franck and Hertz set out to measure just these quantities: ionization potential, electron mean free path, and energy loss in collisions. But first ...

QUANTUM THEORY

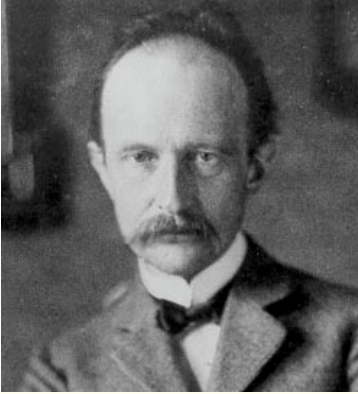

Max Planck



Physical Institute
University of Berlin

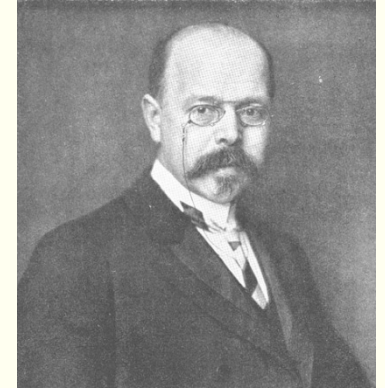

Walther Nernst

That colloquium was the greatest event in my life. There all the professors of physics, and not only of the University but also of the Technical University and ... the Bureau of Standards — everyone who was interested in science came to these things...

I believe the reason that many of us who went into physics at that time tried to do something with quantum theory, is that we went to that colloquium.

James Franck, 1962

FRANCK AND HERTZ, OCTOBER 1911

On a Connection between the Quantum Hypothesis and the Ionization Potential

Not the central motivation, but not quite an afterthought

quantum theory: **ionization energy** = $h\nu$

But what is the frequency ν ?

Franck and Hertz suggested the frequency of the “**selective photoelectric effect**” in alkali **metals** (discovered by Robert Pohl and Peter Pringsheim) might apply to **gases**. (spurious “resonance” effect; don’t ask)

A theory by Friedrich Lindemann related the selective photoeffect frequency to **atomic radius**.

Pohl, Pringsheim, and Lindemann were all at the University of Berlin.

calculate or measure $\nu_{\text{selective photoeffect}}$

measure ionization potential, see if

ionization energy = $h\nu_{\text{selective photoeffect}}$

In the near future, we will attempt to determine the ionization potential of a series of gases directly ... , and hope thus to contribute to an experimental clarification of the question.

FRANCK AND HERTZ, OCTOBER 1911

On a Connection between the Quantum Hypothesis and the Ionization Potential

In their later years, both Franck and Hertz seemed a little embarrassed by this paper. Franck, in his 1962 interview for the Archive on History of Quantum Physics, said he could not remember it.

Hertz, in his 1963 AHQP interview, was positively dismissive:

I believe we do not need to go into it any further.

Nevertheless, they kept coming back to this scheme and possible alternatives, and thus were fully prepared when in 1914 they did find a clear quantum effect.

FRANCK AND HERTZ, JANUARY 1913

Measurement of the Ionization Potential in different Gases

repels electrons but attracts positive ions

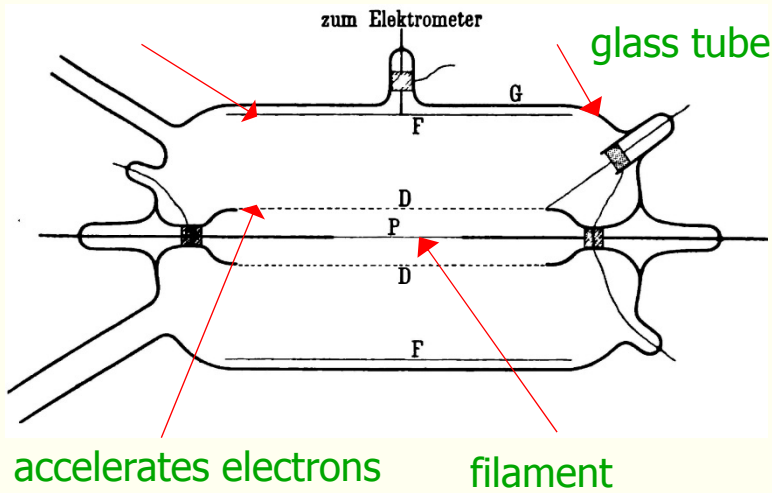

design adapted from Phillip Lenard, who had tried to measure ionization energies by **directly detecting positive ions**

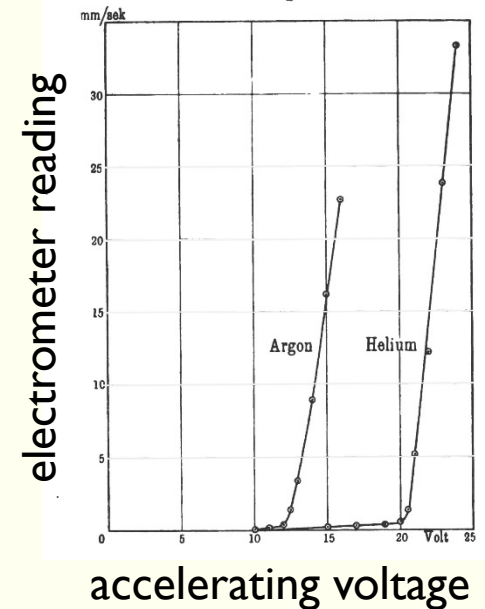

The experiment was designed to measure the ionization potentials of helium, argon, and several other gases at low pressures by detecting (**what they thought were**) positively charged ions. In fact, were seeing **photoelectrons ejected from the collecting electrode**.

Design emphasized cleanliness, eliminating contaminants

- electrical leads fused into the glass tube—no vacuum grease seals
- carefully purified gases
- platinum electrodes
- carefully washed; filament degassed under high vacuum (Gaede pump, liquid air cold traps)

FRANCK AND HERTZ, JANUARY 1913

	helium	neon	argon	hydrogen	oxygen	nitrogen
Townsend	14.5		17.3	26		27.6
Franck-Hertz	20.5	16	12	11	9	7.5
Lenard	about 11 volts for all gases measured					

Franck and Hertz were in fact seeing photoelectrons leaving their collector, not positive ions arriving. In a modern picture, they were measuring the energy of an excited state of the atom, not the ionization energy.

From our measurements we drew the in fact correct conclusion that the noble gases helium and neon had the highest ionization potentials of all gases, and that therefore their behavior in gas discharge [at high pressures] can by no means be explained by extremely low values of the ionization potential in the sense of Townsend's theory. Hence there remained only the possibility of extremely large mean free paths of electrons in noble gases.

Gustav Hertz, 1966

NATURE OF THE COLLISIONS: 1913

On Collisions between Gas Molecules and Slow Electrons (April 1913)

On Collisions between Gas Molecules and Slow Electrons. II. (July 1913)

MEAN FREE PATH

Electrons are accelerated, pass through mesh into field-free region, under pressures ~ 0.1 mm Hg

- height of field-free region adjustable *under vacuum*, with chains

Kinetic theory: The number n of electrons that continue towards collector (i.e., not “reflected” or absorbed in collisions) as function of vertical distance x is

$$n = n_0 e^{-\frac{x}{\lambda}}$$

It is found in agreement with Lenard that the mean free paths of electrons ... is very close to the free path calculated from kinetic theory.

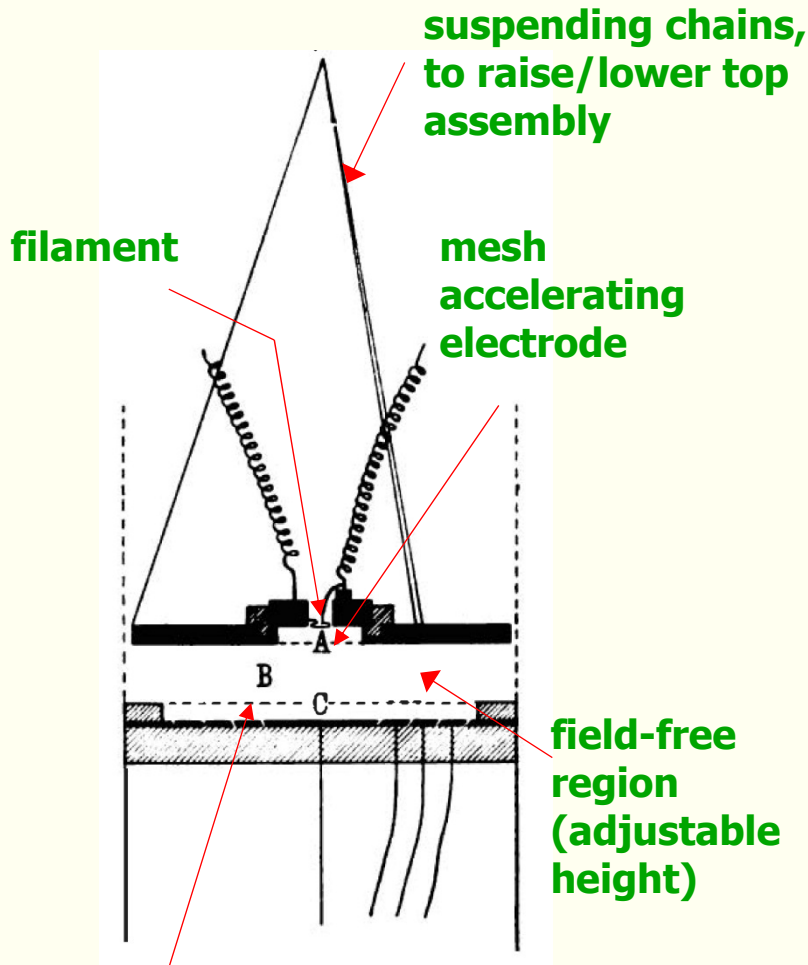

decelerating region
and collecting
electrode

NATURE OF THE COLLISIONS: 1913

On Collisions between Gas Molecules and Slow Electrons (April 1913)

On Collisions between Gas Molecules and Slow Electrons. II. (July 1913)

ENERGY LOSS IN COLLISIONS

A second experiment (using different apparatus) in the April paper that I am leaving out gave preliminary evidence that in helium, at least, electrons lost little if any energy in collisions.

This experiment suggested qualitatively that electrons lost some energy in collision with hydrogen molecules, and even more in collisions with oxygen.

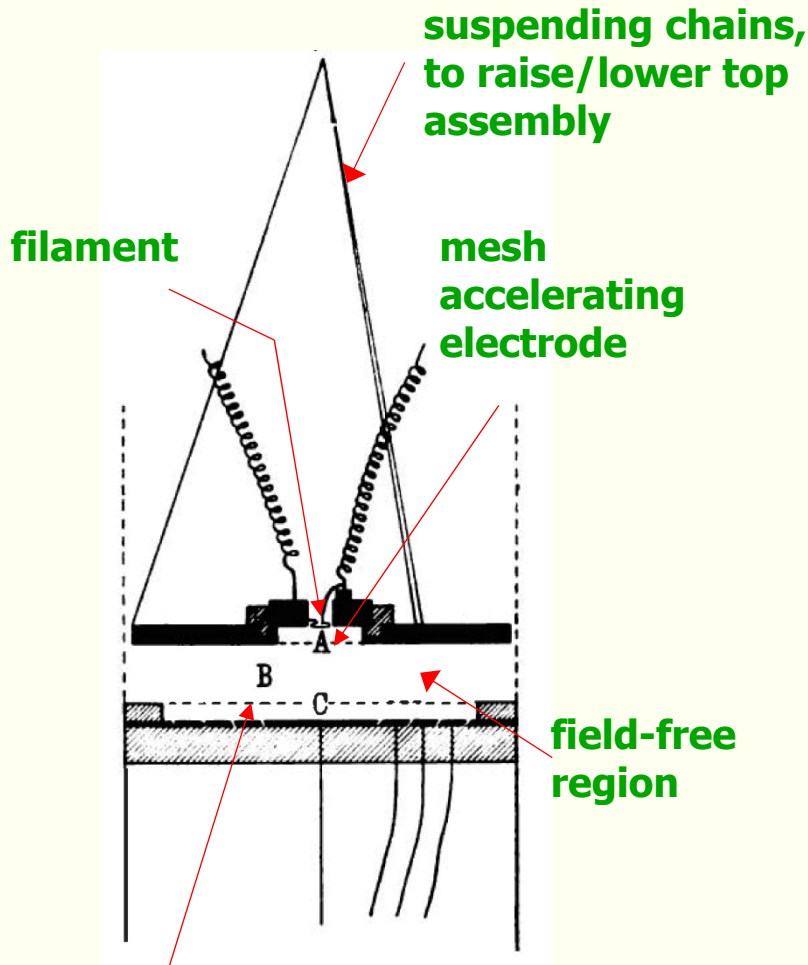

decelerating region
and collecting
electrode

NATURE OF THE COLLISIONS: 1913

On Collisions between Gas Molecules and Slow Electrons (April 1913)

On Collisions between Gas Molecules and Slow Electrons. II. (July 1913)

ENERGY LOSS IN COLLISIONS

They were not satisfied with their April measurements of energy loss, and so redesigned their mfp apparatus to measure energy loss as well. (Diagram is a little misleading.)

- Height of region B adjustable with chains
- electrons accelerated from filament to mesh electrode
- then, subjected to a variable decelerating field in region C
- measurements of current vs. decelerating voltage for different heights gave energy distributions.

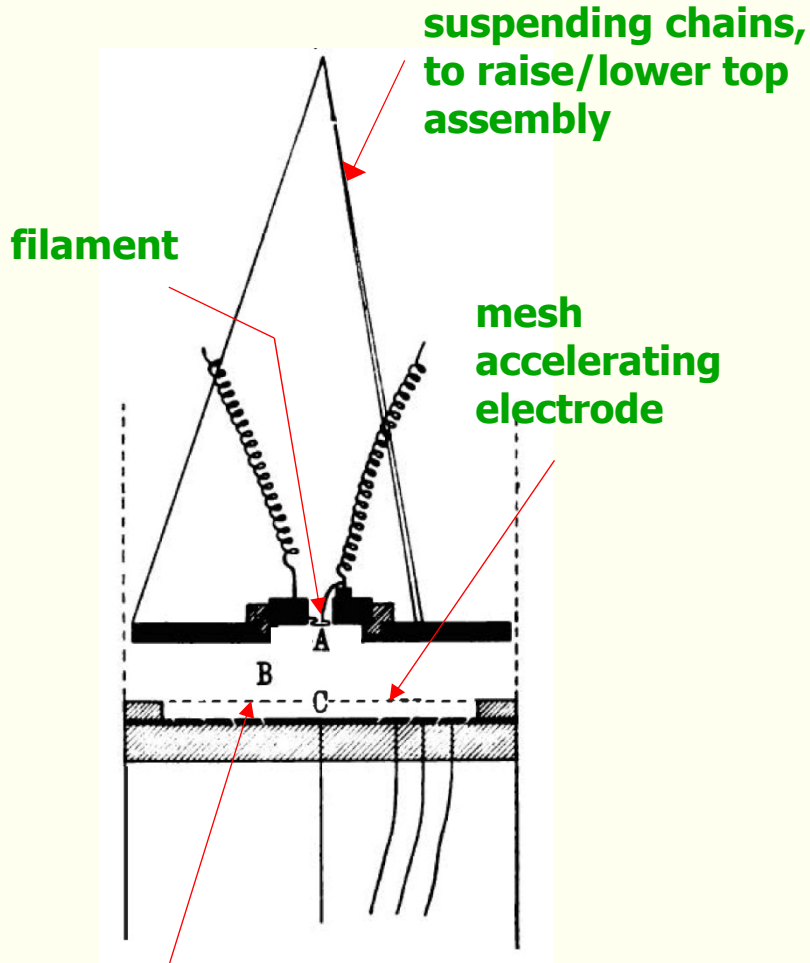

decelerating region
and collecting
electrode

NATURE OF THE COLLISIONS: 1913

On Collisions between Gas Molecules and Slow Electrons. II. (July 1913)

Energy distribution curves

helium: $V_{\text{accel}} = 18\text{V}$

helium: $V_{\text{accel}} = 25\text{V}$

oxygen: $V_{\text{accel}} = 6\text{V}$

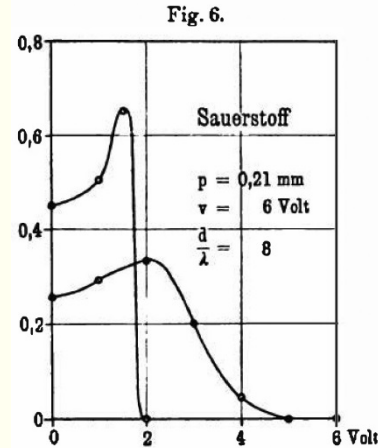
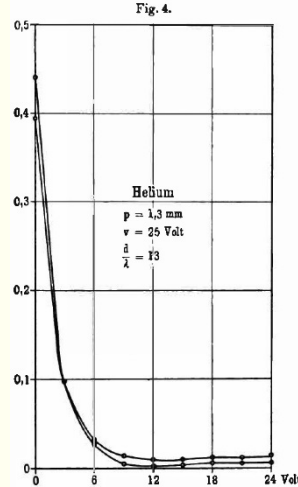
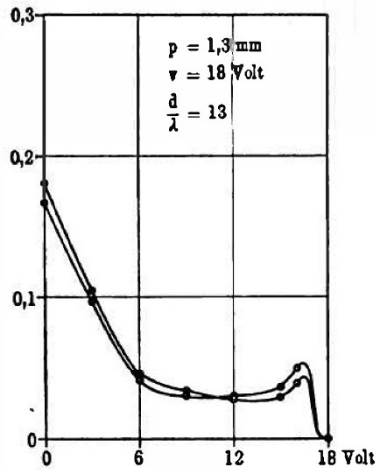

Recall: Critical energy of Helium about 20V

The two curves on each graph represent different heights of region B. (Curves not easy to interpret.)

The collisions between electrons and gas molecules are the more elastic, the smaller the **electron affinity** of the struck gas molecule.

The collisions between electrons and helium atoms are nearly or entirely elastic.... In helium the energy needed for ionization can be gained over **arbitrarily many collisions**.

... the hypothesis of completely inelastic collisions on which Townsend's theory of ionization by collision essentially rests, does not agree with the facts ...

FRANCK AND HERTZ, APRIL 1914

On Collisions between Electrons and Molecules of Mercury Vapor and the Ionization Potential of the Same

In early 1914, Franck and Hertz turned to measurements in mercury vapor, as they had promised more than a year earlier:

Above all the monatomic metal vapors of mercury and the alkalis should be investigated, since Pohl and Pringsheim found the frequency of the selective photoeffect for them.

Franck and Hertz, January 1913

FRANCK AND HERTZ, APRIL 1914

On Collisions between Electrons and Molecules of Mercury Vapor and the Ionization Potential of the Same

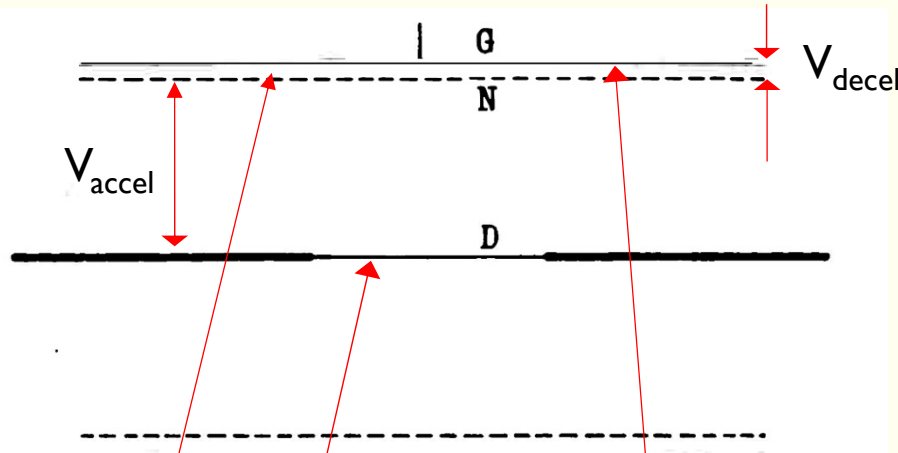

mesh
accelerating
electrode
filament

decelerating region
and collecting
electrode

Results:

- collisions elastic below ~ 5 v
- \Rightarrow "ionization" potential ~ 5 v

- could not use their 1913 method (detect positive ions) for mercury
- suspected that mercury vapor behaved like helium (elastic collisions, no energy loss)
 \Rightarrow used energy distribution technique from 1913— note similarity of apparatus
- measured current vs. **decelerating** voltage, at **constant** accelerating voltage

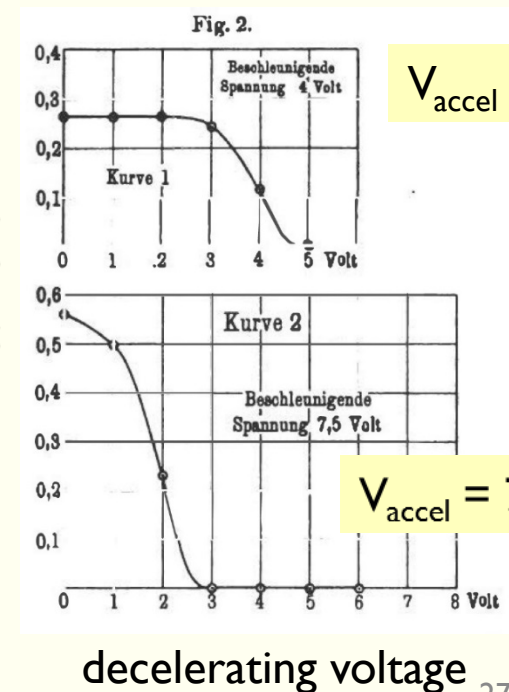

$$V_{\text{accel}} = 4 \text{ V}$$

$$V_{\text{accel}} = 7.5 \text{ V}$$

FRANCK AND HERTZ, APRIL 1914

On Collisions between Electrons and Molecules of Mercury Vapor and the Ionization Potential of the Same

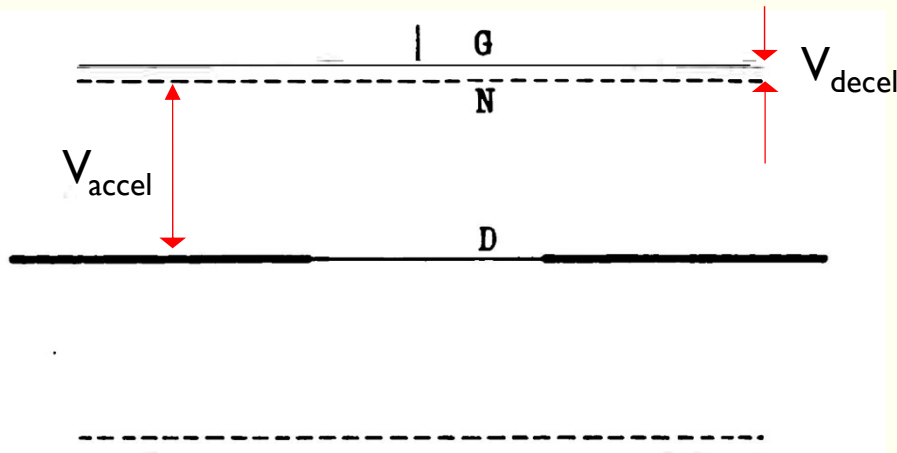

And now comes such a little trick, a small point ...

Gustave Hertz, 1968

Original scheme: measure current vs. **decelerating** voltage, at **constant** accelerating voltage

Change: instead, measure current vs. **accelerating** voltage, at **constant** decelerating voltage

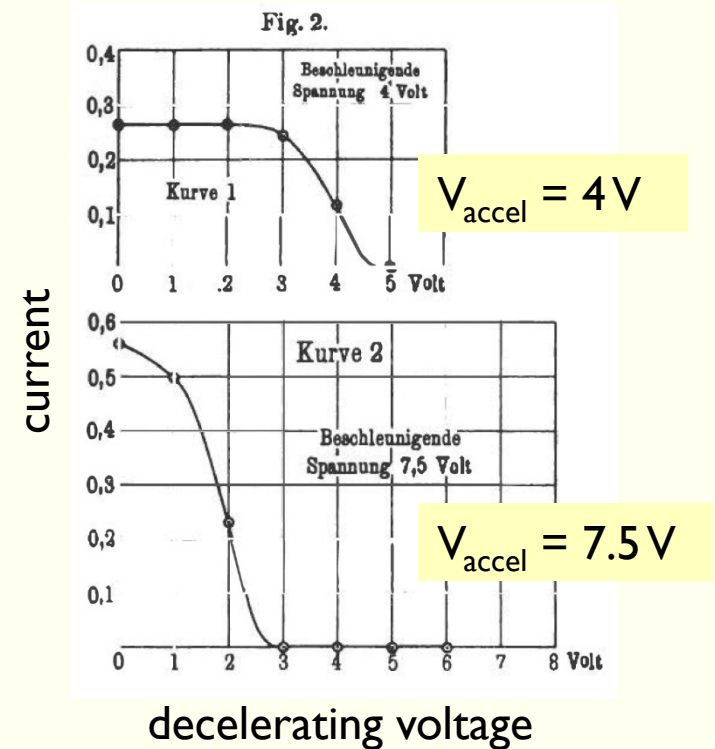

FRANCK AND HERTZ, APRIL 1914

On Collisions between Electrons and Molecules of Mercury vapor and the Ionization Potential of the Same

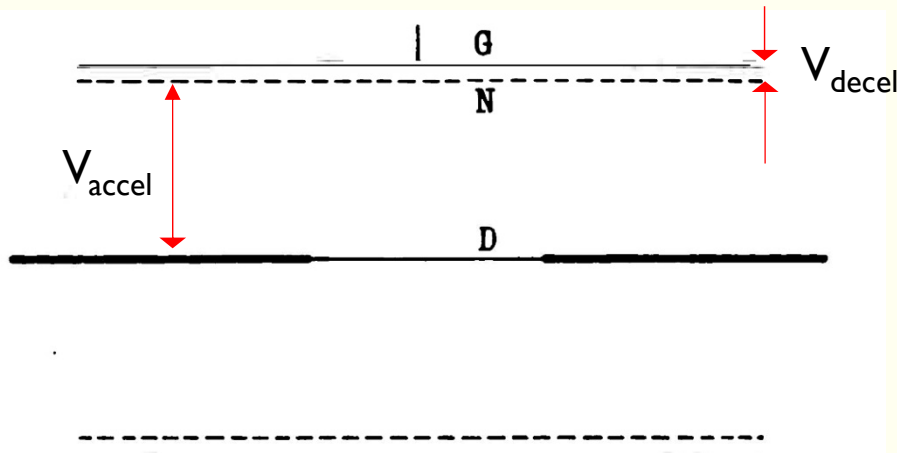

And now comes such a little trick, a small point ...

Gustave Hertz, 1968

Change: instead, measure current vs. **accelerating** voltage, at **constant** decelerating voltage

⇒ much higher accuracy

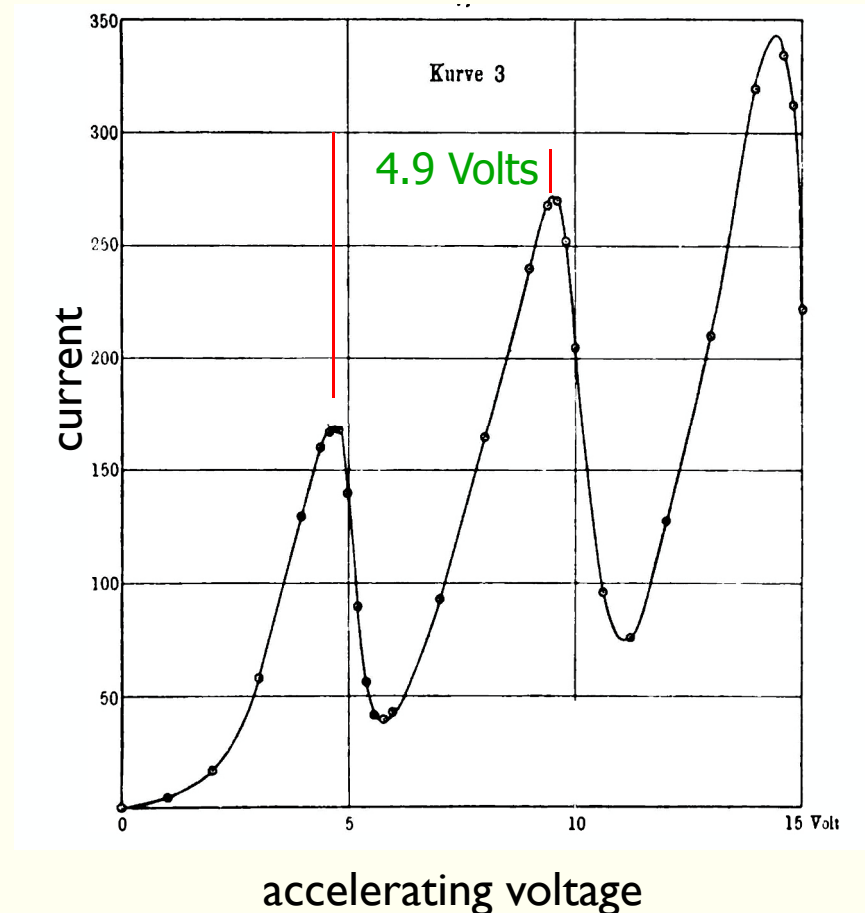

They immediately connected this 4.9 volt spacing to the 2536 Å “resonance” line in mercury.

RESONANCE FLUORESCENCE

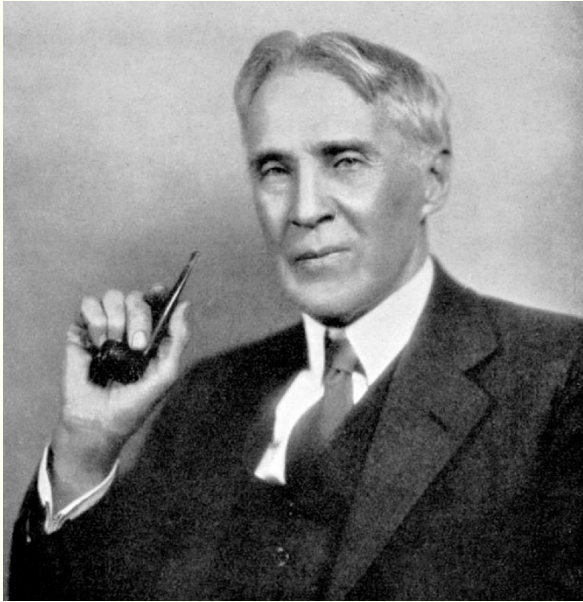

Robert W. Wood

Discovered by the American spectroscopist Robert W. Wood in 1904.

Illuminate sodium vapor at low pressure with a beam of light from sodium D lines. The vapor absorbs the light, and fluoresces (radiates in all directions) with light of the same wavelength.

Ditto for the 2536 Å line in mercury, in 1909.

In other words, we take hold of, and shake, so to speak, but one of the many electrons which make up the molecule.

Robert W. Wood, 1911

Franck and Hertz both said in later years that they knew little about spectroscopy.

But Wood was a frequent visitor to Berlin, and he and Franck had published two papers together.

FRANCK AND HERTZ, MAY 1914

On the Stimulation of the $253.6 \mu\mu$ Mercury Resonance Line by Electron Collisions

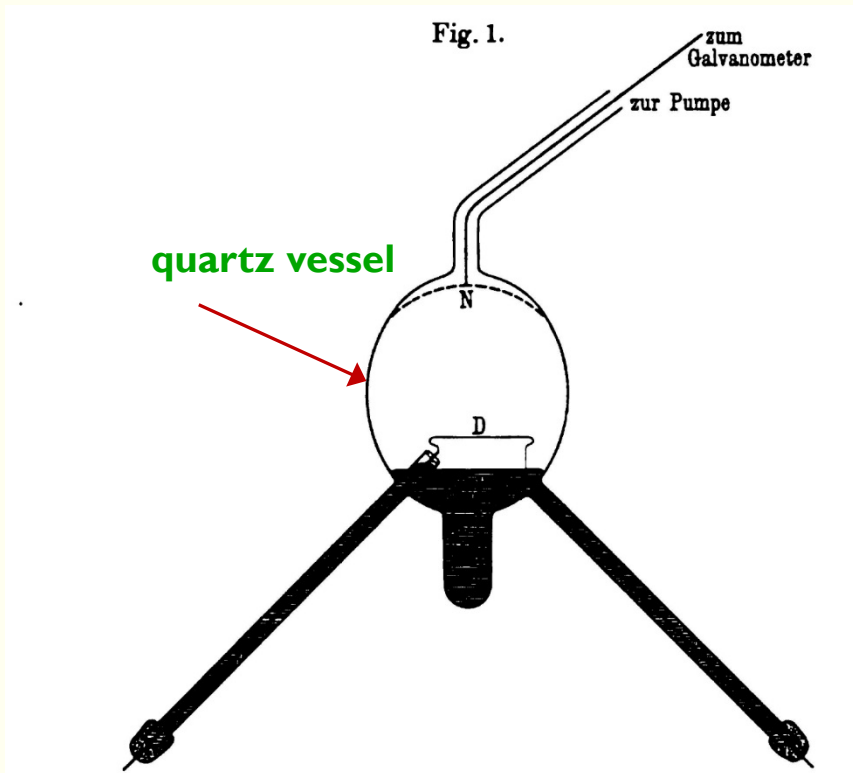

Franck and Hertz confirmed (with a borrowed ultraviolet spectrometer) the presence of the 2536 \AA line of mercury (and only that line), as they raised the accelerating voltage of the electrons in the quartz vessel through 4.9 volts.

FRANCK AND HERTZ, APRIL–MAY 1914

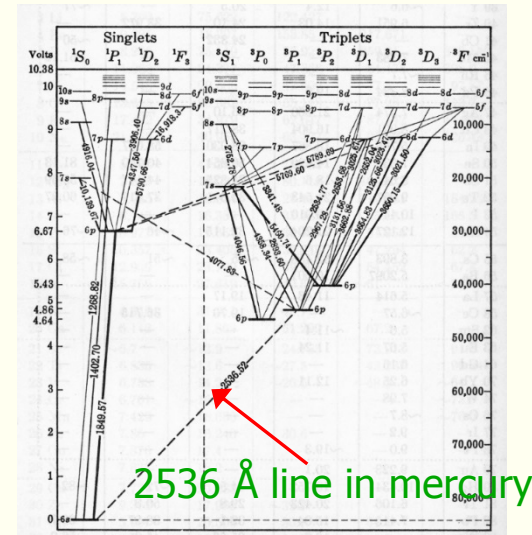
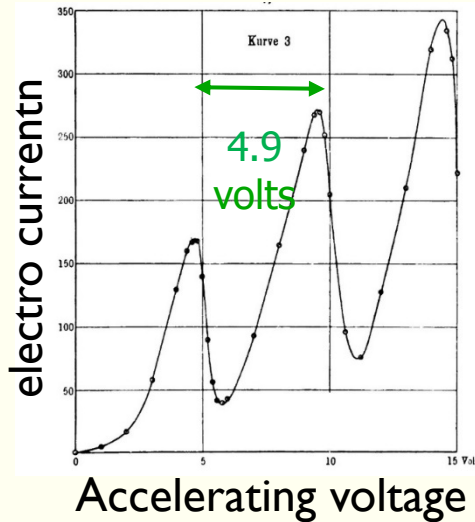

In 1914, Franck and Hertz:

- still thought they were seeing ionization, though they knew they were not seeing positive ions directly
- used older (Thomson-like) model of atom; electrons acted like quantized Planck oscillators
... as proven through Wood's experiment on mercury resonance radiation, in every mercury atom an electron is present that can oscillate with a frequency corresponding to the wavelength 253.6 μm .
- had a surprising picture of ionization and light emission
Part of the collisions lead to ionization ... Another part appears to lead to light excitation, consisting of the emission of the 253.6 μm line.

THE FRANCK-HERTZ EXPERIMENTS AND BOHR'S THEORY DURING THE GREAT WAR

World War I began in August 1914. Franck and Hertz both found themselves in the Army. Hertz was badly wounded in 1915. Franck became seriously ill twice, once on the western front, the second time in the east. Both took many months to recover. Neither resumed experimental work until after the war.

Bohr published the first installment of his three-part paper “On the Constitution of Atoms and Molecules” in July 1913, not quite a year before Franck and Hertz’s papers on mercury appeared.

Franck and Hertz did not so much as mention Bohr’s paper in 1914, and it is not clear whether they knew about it. As we have seen, they used an older picture of the atom to interpret their results. Even in a 1916 paper, they sounded skeptical.

So how did the Franck-Hertz experiments come to be seen as confirming Bohr’s picture?

NIELS BOHR – 1913 AND 1915



Niels Bohr (1885–1962)

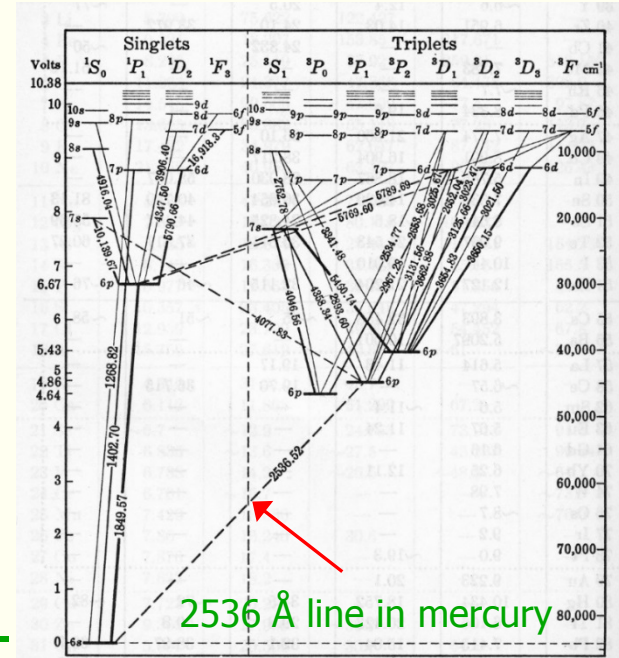

1913:

- best known for quantization of angular momentum, derivation of Balmer series in H;
- Spectroscopic “terms” became energy levels; spectral lines \Rightarrow energy differences between terms
- ionization potential: limit of terms ending on lowest energy state

1915:

- Bohr suggested that Franck and Hertz were **not** seeing ionization, but instead, photoelectrons mimicking ionization

NIELS BOHR – 1913 AND 1915



Niels Bohr (1885–1962)

Balmer Series

$$\nu = R \left(\frac{1}{3^2} - \frac{1}{n^2} \right)$$

10.4 eV

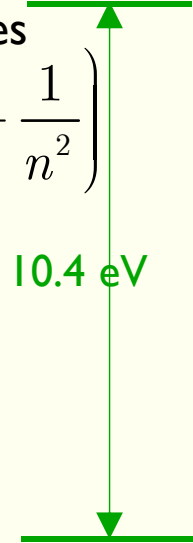
A diagram showing two horizontal green lines representing energy levels. A vertical green double-headed arrow connects the two lines, with the text '10.4 eV' written next to it. The top line is higher than the bottom line.

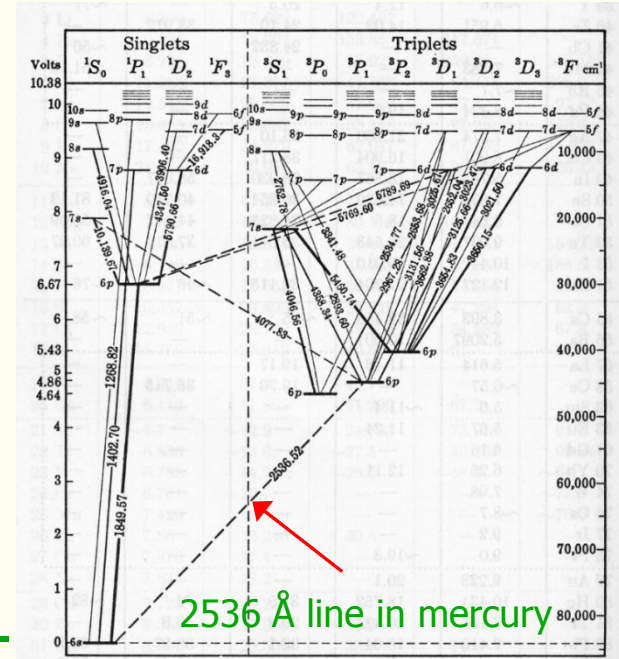

1913:

- best known for quantization of angular momentum, derivation of Balmer series in H;
- Spectroscopic “terms” became energy levels; spectral lines \Rightarrow energy differences between terms
- ionization potential: limit of terms ending on lowest energy state

1915:

- Bohr suggested that Franck and Hertz were **not** seeing ionization, but instead, photoelectrons mimicking ionization

ENTER THE NORTH AMERICANS

1. **John T. Tate**, 1916, 1917; Universities of Nebraska, Minnesota. Tate received his Ph.D. in 1914, from the U of Berlin, where he had met Franck!
2. John C. McLennan, 1915, 1916; University of Toronto
3. Hendrik Johannes van der Bijl, 1917; South African physicist working at the Research Laboratory, Western Electric Company (later Bell Laboratories)
4. Thomas C. Hebb and Robert W. Millikan, 1917, University of Chicago
5. **Bergen Davis and Frederick S. Goucher**, 1917; Columbia University

Most were (or later became) well known. McLennan was President of Section A of the BAAS in 1924. Davis was one of the first physicists at Columbia to develop a significant experimental research program. Van der Bijl later became a Fellow of the Royal Society. Millikan later won the Nobel Prize. Hebb became physics chair at the University of British Columbia; their physics building is named after him. And Tate was later Editor of the Physical Review; the Minneapolis campus physics building is named after him.

McLennan and Davis both spent a year or so at the Cavendish, working with J. J. Thomson. Goucher earned his PhD with Davis, and went on to a long and successful career in industry.

All, to a greater or lesser extent, challenged Franck-Hertz's interpretation of their electron collision experiments in mercury, and mentioned and often supported Bohr's theory.

JOHN T. TATE, APRIL 1916



John Torrence Tate
(1889–1950)

“The Low Potential Discharge Spectrum of Mercury Vapor in relation to Ionization Potentials.” Abstract of a paper given at the April 1916 American Physical Society meeting and published in Physical Review.

It has been shown by Franck and Hertz that collisions between electrons ... and atoms of mercury vapor are elastic for velocities of the electrons less than 4.9 volts.

Incidentally the writer has repeated the measurements of Franck and Hertz very carefully and has obtained a value of 4.90 ± 0.03 volts for the critical velocity. ... All that is clearly demonstrated is that the collisions become inelastic at that point. **It is readily conceivable ... that the energy lost by the colliding electron merely goes over into energy of agitation of the electrons bound in the atom and not necessarily into completely separating one or more electrons from the atom.**

JOHN T. TATE, APRIL 1916



John Torrence Tate
(1889–1950)

It was found that with velocities corresponding to total effective potentials of more than about 5 volts and less than 10 volts the spectrum consisted of a single line of wave-length $253.67 \mu\mu$. At about 10.3 volts the many-lined spectrum of mercury began to appear

The results of the investigation show ... that a marked ionization occurs in mercury vapor when the velocity of the colliding electrons reaches a critical value of 10.0 volts (possible error about .3 volt). **This is very nearly the value (10.2 volts) to be expected on the basis of Bohr's theory of the atom**

although ionization of mercury vapor at 4.9 volts is not definitely disproved it is certainly much less complete than the ionization taking place at 10.0 volts.

HENDRIK JOHANNES VAN DER BIJL, 1916



Hendrik van der Bijl
(1887–1948)

South African physicist working at the Western Electric Research Laboratory in New York

proposed photoelectric interpretation in 1916, independent of Bohr; influenced Davis and Goucher

When the electron acquires energy equivalent to 4.9 volts in the case of mercury ... the corresponding line 2536 is emitted. There is thus created a source of ultra-violet light in the tube. This light falls on the plate which is connected to the electrometer and so can emit electrons from the plate photoelectrically, thus causing the electrometer to charge up positively. It is just possible that this is what was measured.

... such a result, should it receive experimental corroboration, would possibly be capable of explanation on Bohr's theory, but there is a question as to whether such a thing as a definite ionizing potential of an element exists at all.

THOMAS HEBB AND ROBERT MILLIKAN, 1917



Robert A. Millikan
(1868–1953)

Hebb, working in Millikan's laboratory at the University of Chicago, bombarded mercury atoms with a "dense" electron stream

- Between 5 and 10 volts, he observed the mercury resonance line
- But he also saw, very faintly, the full spectrum of mercury.



Thomas C. Hebb
(1878–1938)

In a paper immediately following in the *Physical Review*, Millikan interpreted Hebb's results as **ionization by multiple collision**, and argued that such an interpretation supported Bohr's theory.

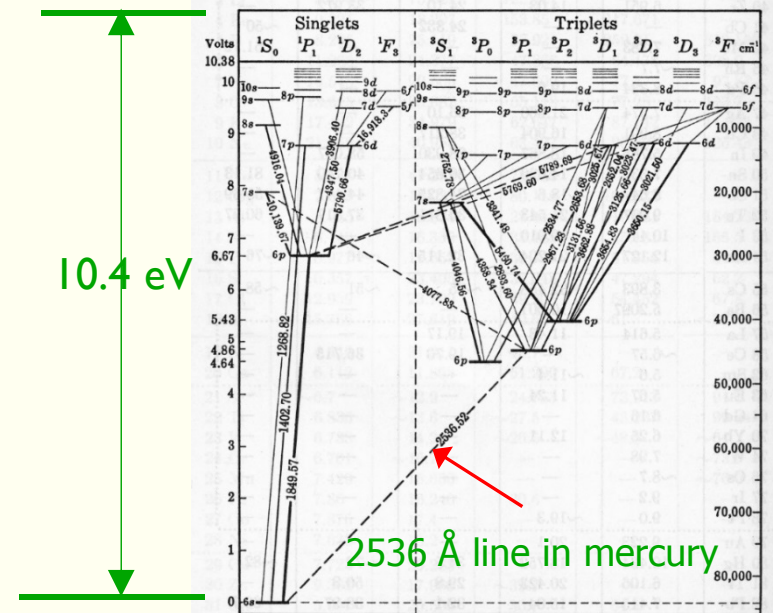

BERGEN DAVIS AND FREDERICK GOUCHER, 1917



Bergen Davis
(1869–1958)

Goucher, in his PhD experiment under Davis's direction at Columbia University in New York, returned to Lenard's method of directly detecting positive ions, and contrived a clever technique for distinguishing between positive ions arriving at the collecting electrode, and photoelectrons leaving.



Frederick S. Goucher
(1888–1973)

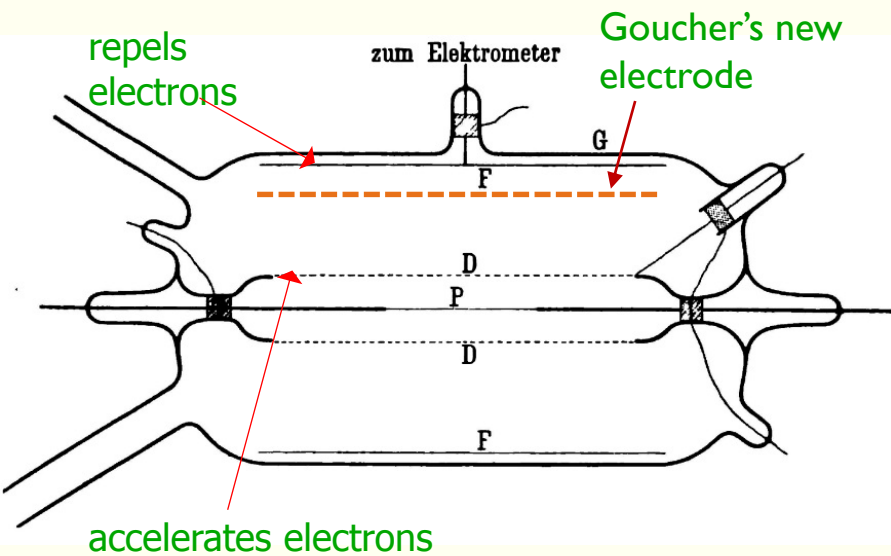

Goucher's new electrode could be biased either positively or negatively with respect to the collecting electrode *F*

- In this way, they could control behavior of both photoelectrons and positive ions and distinguish between them

Their results were unambiguous

- 4.9 volts \Rightarrow photoelectrons
- 10.2 volts \Rightarrow positive ions

These results are of considerable interest when considered from the point of view of the Bohr theory of the atom.

FRANCK AND HERTZ, 1919

The Confirmation of Bohr's Atomic Theory through Investigations of Inelastic Collisions of Electrons with Gas Molecules

Franck and Hertz, January 1919

In January 1919, barely two months after the armistice, Franck and Hertz published a long review article. They had learned of the North American work and by now had become enthusiastic proponents of Bohr's theory. They fully understood how their experiments, looked at from this new perspective, supported that theory.

Moral:

Good experiments can succeed even when guided by mistaken theories. And the interpretation of those experiments can change, sometimes radically, when theoretical pictures change.